

Produced by the United States Geological Survey 1988
Revision within and adjacent to National Forest System lands by USDA Forest Service 1996

Compiled from aerial photographs taken 1975. Revised from aerial photographs taken 1994. Contours have not been revised.

North American Datum of 1927 (NAD 27). Projection and 10 000-foot ticks: California coordinate system, zone 6 (Lambert conformal conic). Blue 1000-meter Universal Transverse Mercator ticks, zone 11.

North American Datum of 1983 (NAD 83) is shown by dashed corner ticks. The values of the shift between NAD 27 and NAD 83 for 7.5-minute intersections are obtainable from National Geospatial Survey NADCON software.

Non-National Forest System lands within the National Forest. Inholdings may exist in other National or State reservations.

This map is not a legal land line or ownership document. Public lands are subject to change and leasing, and may have access restrictions; check with local offices. Obtain permission before entering private lands.

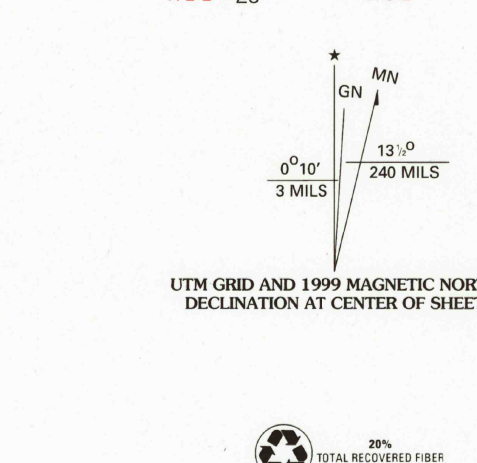

SCALE 1:24 000

CONTOUR INTERVAL 40 FEET
NATIONAL GEODETIC VERTICAL DATUM OF 1929
TO CONVERT FEET TO METERS MULTIPLY BY 0.3048

THIS MAP COMPLIES WITH NATIONAL MAP ACCURACY STANDARDS
FOR SALE BY U.S. GEOLOGICAL SURVEY, P.O. BOX 25286, DENVER, COLORADO 80225
A FOLDER DESCRIBING TOPOGRAPHIC MAPS AND SYMBOLS IS AVAILABLE ON REQUEST

1	2	3	1 Blackburn Canyon
			2 Idyllwild
			3 Palm View Peak
4	5		4 Cahuilla Mountain
			5 Butterfly Peak
			6 Aguanga
6	7	8	7 Beauty Mountain
			8 Backsoot Mountain

HIGHWAYS AND ROADS

- Interstate:
- U. S.:
- State:
- County:
- National Forest, suitable for passenger cars:
- National Forest, suitable for high clearance vehicles:
- National Forest Trail:

ROADS

- Primary highway:
- Secondary highway:
- Light-duty road:
- Paved:
- Gravel:
- Dirt:
- Composition unspecified:
- Unimproved; 4 wheel drive:
- Trail:
- Gate; Barrier:

ANZA, CA 1996
NIMA 2651 II SW - SERIES V895

