

Mapped, edited, and published by the Geological Survey  
Control by USGS and USC&GS  
Topography from aerial photographs by photogrammetric methods  
Aerial photographs taken 1947. Field check 1951  
Polyconic projection. 1927 North American datum  
10,000-foot grid based on California coordinate system, zone 5  
Dashed land lines indicate approximate locations  
Unchecked elevations are shown in brown  
1000-meter Universal Transverse Mercator grid ticks,  
zone 11, shown in blue

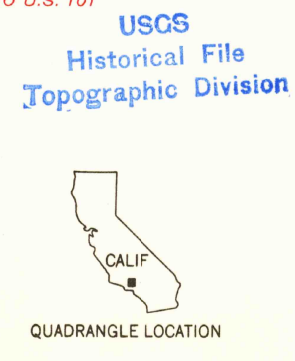
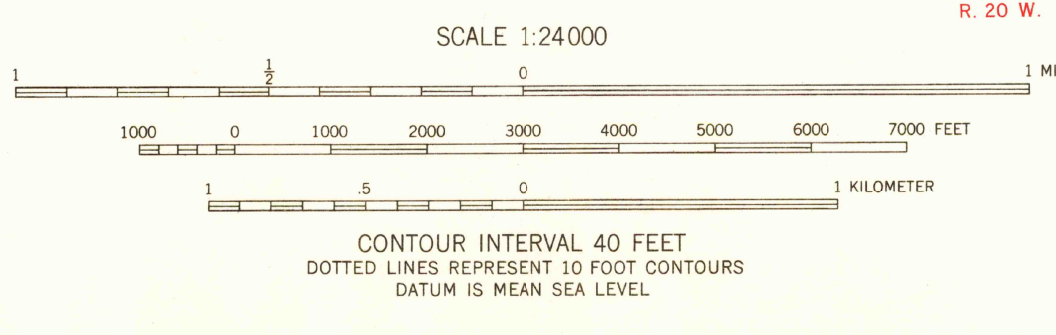
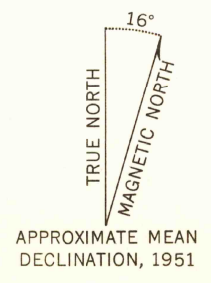

ROAD CLASSIFICATION

Heavy-duty	Light-duty
Medium-duty	Unimproved dirt
	State Route

THIS MAP COMPLIES WITH NATIONAL MAP ACCURACY STANDARDS  
FOR SALE BY U. S. GEOLOGICAL SURVEY, DENVER 25, COLORADO OR WASHINGTON 25, D. C.  
A FOLDER DESCRIBING TOPOGRAPHIC MAPS AND SYMBOLS IS AVAILABLE ON REQUEST

FILLMORE, CALIF.  
NW/4 PIRU 15' QUADRANGLE  
N3422.5-W11852.5/7.5

1951

AUG 23 1980

4130