

Produced by the United States Geological Survey 1963
Revision within and adjacent to National Forest System lands
by USDA Forest Service 2002
Topography compiled 1963. Planimetry derived from imagery taken 1996
and other sources. Public Land Survey System and survey control current
as of 2002
North American Datum of 1927 (NAD 27). Projection and 10 000-foot ticks:
New Mexico coordinate system, central zone (transverse Mercator)
Blue 1000-meter Universal Transverse Mercator ticks, zone 13
North American Datum of 1983 (NAD 83) is shown by dashed corner ticks
The values of the shift between NAD 27 and NAD 83 for 7.5-minute
intersections are obtainable from National Geodetic Survey NADCON software
Non-National Forest System lands within the National Forest
holdings may exist in other National or State reservations
This map is not a legal document. Public lands are subject to
change and leasing, and may have access restrictions; check with
appropriate offices. Obtain permission before entering private lands

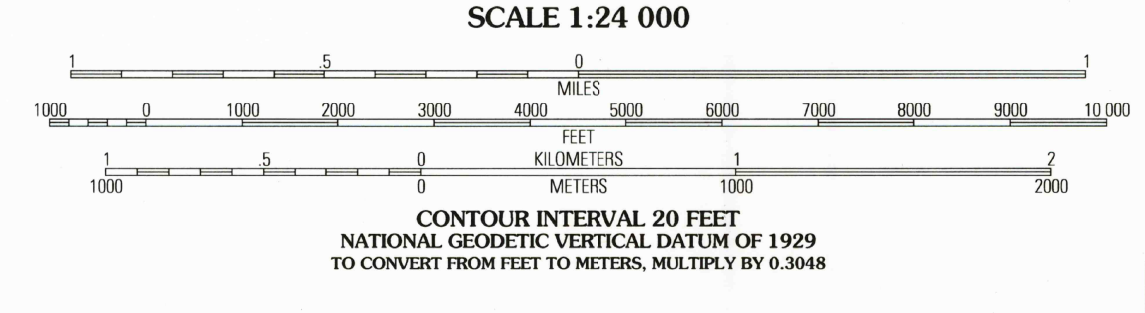
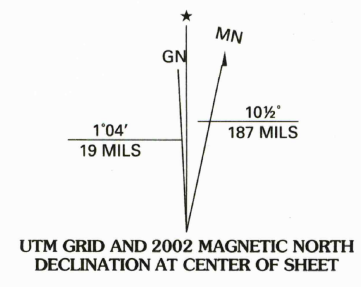

1	2	3	1 Laguna Garule
4	5	4	2 French Mesa
6	7	5	3 Laguna Peak
		6	4 Regina
		7	5 Arroyo del Agua
		8	6 Cuba
			7 Nacimiento Peak
			8 Jarosa

ADJOINING 7.5' QUADRANGLES

HIGHWAYS AND ROADS

Interstate	Primary highway
U. S.	Secondary highway
State	Light-duty road
County	Composition: Unspecified
National Forest, suitable for passenger cars	Paved
National Forest, suitable for high clearance vehicles	Gravel
National Forest Trail	Dirt
			Unimproved; 4 wheel drive
			Trail
			Gate; Barrier

GALLINA, NM
2002
36106-B7-TF-024
NMA 4656 III NE-SERIES V881

USGS Library
Reston, VA
Topo Archive



3 1818 00418428 7