

Mapped, edited, and published by the Geological Survey
Control by USGS and USC&GS
Topography from aerial photographs by multiplex methods
Aerial photographs taken 1942. Field check 1944
Culture revised 1953
Polyconic projection. 1927 North American datum
10,000-foot grids based on Pennsylvania coordinate system,
south and north zones
1000-meter Universal Transverse Mercator grid ticks,
zone 18, shown in blue
Revisions shown in purple compiled in cooperation with
State of Pennsylvania agencies from aerial photographs
taken 1969 and 1976. This information not field checked

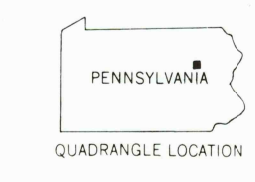
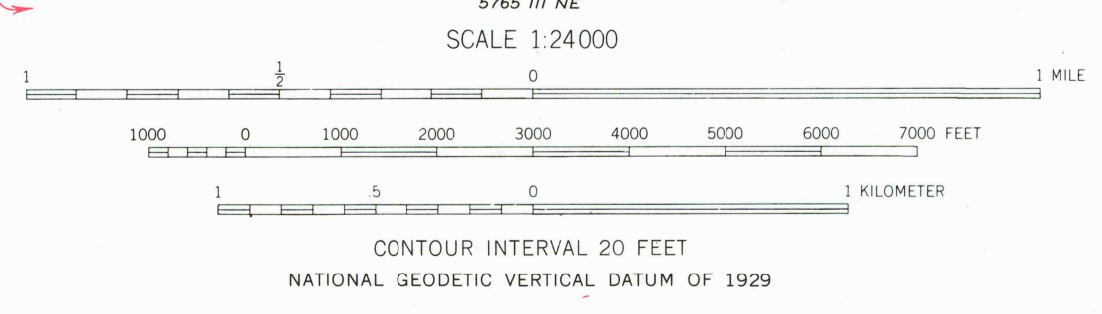
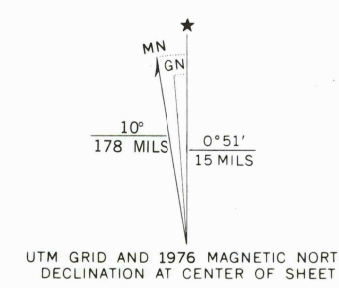

ROAD CLASSIFICATION
Heavy-duty ——— Light-duty ———
Medium-duty ——— Unimproved dirt ———
U.S. Route —○— State Route —○—
Interstate Route —○—
USGS Historical File Division
ASHLAND, PA.
N 4045—W 7615/7.5
1953
PHOTOREVISED 1969 AND 1976
AMS 5765 IV SE—SERIES 7631

JUN 22 1978
3900

THIS MAP COMPLIES WITH NATIONAL MAP ACCURACY STANDARDS
FOR SALE BY U.S. GEOLOGICAL SURVEY, RESTON, VIRGINIA 22092
A FOLDER DESCRIBING TOPOGRAPHIC MAPS AND SYMBOLS IS AVAILABLE ON REQUEST